

2DX | THE SMARTER PERFORMER



JCB 2DX

Right Backhoe Loader for smart jobs

Excavator fuel efficiency



JCB 2DX offers excellent fuel efficiency, making it a sound investment.

Low cost, high profit

When given on hire, it provides the highest income in this segment.



Designed for compact areas & utility jobs

Given its compact size, it is ideal for reaching and manoeuvring through inaccessible areas.



700+ outlets with trained engineers



Widespread dealer network results in best after-sales services for higher uptime.

A Product of Hard Work



*T & C Apply.

Productivity & reliability

Given the high quality machine that it is, it offers the highest productivity and reliability.



Versatility

A wide array of attachments such as high dump bucket, 6-in-1 bucket, auger, dozer blade make the machine more versatile.



Safety & comfort

Enabled with added safety features, JCB 2DX offers enhanced security and operator comfort.



Style & design

It is designed for better visibility and also comes with an open canopy with front glass.



Warranty

JCB 2DX Backhoe Loader comes with JCB warranty on full machine.



Easy finance & registration

Attractive and easy finance schemes are made available by many financiers for the purchase of JCB 2DX. It can be easily registered at all RTO's across India.



JCB 2DX comes with cabin, high dump bucket and 6-in-1 shovel.

Engine Performance

**LOW FUEL
CONSUMPTION**



- Highly fuel efficient & powerful water cooled diesel engine developing 36.4 kW (49 hp) @ 2200 RPM.
- Easy to maintain in-line fuel pump.
- Water separator provided for getting more reliability and longer fuel pump life.
- Long service intervals (500 hrs) for achieving better economy.
- Confirming to emission norms as per CMVR Bharat Stage III.

- JCB synchroshuttle provides superb driving power in all conditions.
- Consists of 4 speed, fully synchromesh, smooth shift gear box with integral torque convertor.
- Torque convertor stall ratio is 3.01:1



Durable & Reliable JCB Transmission



**High dump shovel model
with dump height of 3.1 m**

Robust Structure

- JCB manufacturing process ensures consistent quality and reliability.
- Structural integrity achieved through rigorous design involving F.E.A. and strain gauging.
- Robust and heavy duty structure made of high quality steel.

Incredible Productivity

- The 2610 PSI hydraulic system pressure allows higher tear out force enabling the machine to dig hard ground with higher productivity.
- JCB equal length boom and dipper design ensures digging close to the machine, improves visibility to the trench.
- Durable loader arm design with high break out force and lift capacity.
- 28 Km/hr travel speed for faster coverage of long distances.

Major Applications



Brick kiln



Rubber / Coconut plantation



Animal farm & biogas plant



Rural infrastructure & square hole



Irrigation sites, rain-water harvesting & top soil turning



Trenching & pipe laying



Auger (drill) for plantation, fencing & light pole



Coal & limestone factory loading / unloading



Municipal solid waste management

Major Applications



Hopper feeding for ready mix concrete



Spices (red chilli) / Chemical plant



Cotton factory



High dumper (hywa) loading



Husk handling



Paper factory (recycling)



Cleaning of sewages



Basement construction



Loading with 6-in-1 bucket

PERFORMANCE DIMENSIONS

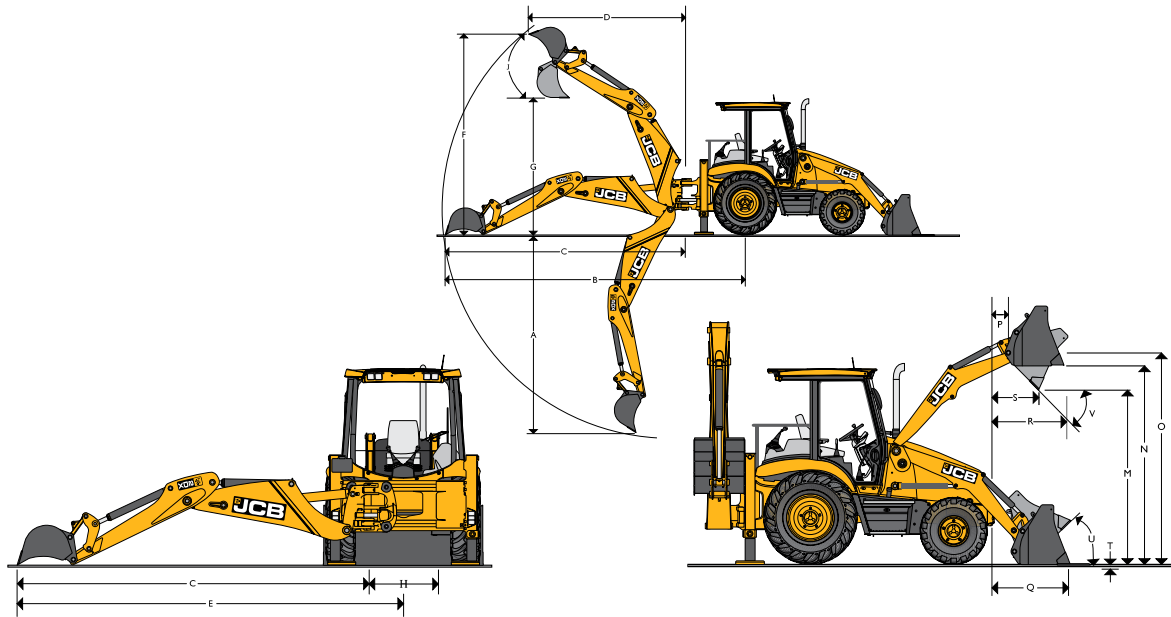

EXCAVATOR PERFORMANCE

A	Max. dig depth	m	3.02
B	Reach-Ground level to rear wheel centre	m	5.14
C	Reach- Ground level to slew centre	m	3.93
D	Reach at full height to slew centre	m	1.81
E	Side reach to centre line of machine	m	4.36
F	Max. working height	m	3.88
G	Max. load over height	m	2.74
H	King post travel	m	0.86
J	Bucket rotation - Power		182°
	Bucket tear out force	kgf	3120
	Dipper tear out force	kgf	1750
	Lift capacity to bucket pivot at full reach (No bucket fitted) (SAE J31) (Data with standard dipper)	kgf	1490
	Bucket capacity	cu.m	0.18

LOADER PERFORMANCE

	Shovel Capacity	cum	0.60
M	Dump height	m	2.3
N	Load over height	m	2.83
O	Pin height	m	3.00
P	Pin forward reach	m	0.37
Q	Reach at ground	m	1.3
R	Max. reach at full height	m	1.12
S	Reach at full height - Bucket dumped	m	0.79
T	Below ground level dig depth	m	0.09
U	Rollback at ground		46°
V	Dump angle		44°
	Shovel break out force	kgf	3370
	Loader arm break out force	kgf	1834
	Payload	kgf	800
	Lift capacity to full height	kgf	1620

STATIC DIMENSIONS

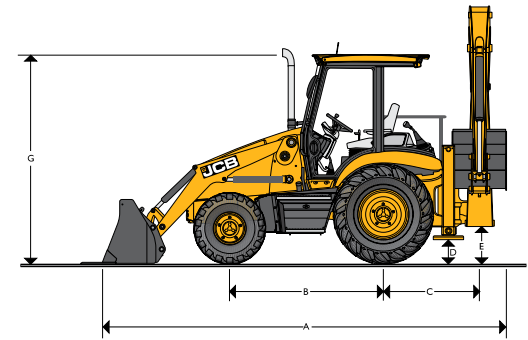

STATIC DIMENSIONS

A	Overall length	m	5.5
B	Wheelbase	m	2.08
D	Minimum ground clearance	m	0.33
E	Slew ground clearance	m	0.484
G	Height to top of cab	m	2.70
H	Overall height	m	2.65
J	Track width - Rear	m	1.42
K	Track width - Front	m	1.62
L	Width over bucket	m	1.912

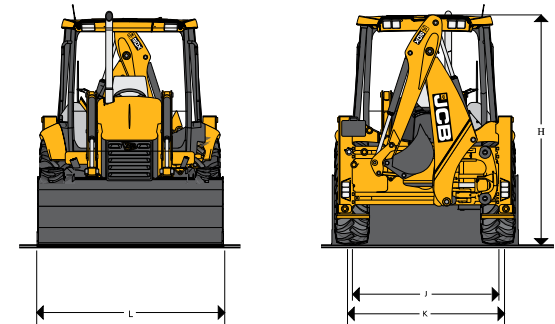

ENGINE

KOEL 4R810, NA, water cooled, BSIII diesel engine.

No of cylinders : 4, displacement : 3.2 litres,

Gross power : 36.4 kW (49 hp)

Max torque : 203 Nm @ 1400 RPM (as per SAEJ 1995)

TRANSMISSION

The JCB. SS 700 synchroshuttle transmission. It consists of a 4-speed, fully Synchromesh, smooth shift gearbox with integral torque converter and electrically operated reversing shuttle.

- Easy to use, column mounted electric reversing shuttle switch can change machine direction while allowing operator to keep hands on the steering wheel leading to fast cycle time.
- The Pedals layout and conventional 4-pattern gear lever with transmission switch adds to the overall ease of operation.
- Torque converter stall ratio 3.01:1.

BRAKES

- Service : Hydraulically actuated, dual line, self-adjusting (compensated), oil immersed, multi-disc type on the rear axle, well protected from dirt, water, etc. Operated through independent pedals linked together for normal use. Two independently operating foot pedals enable machine to maneuver in tight spaces.
- Hand operated disc brakes on rear axle input disc.

STEERING

Full power, front wheel hydrostatic power steering with power track road and manual capability in the event of engine or hydraulic power failure.

Hydraulic supply from pump via priority valve. Working pressure 1810 p.s.i (125 bar).

ELECTRICALS

100 Ampere-hour 12 V battery system with alternator and full road lighting.

TYRES

Front	7.5 x 16 - 16 PR (Industrial tyre)
Rear	12 x 24 - 20 PR 14.9 x 24 - 12 PR (Heavy-duty tyre)

TURNING CIRCLE

Inner wheels braked		2WD
A	Outside loader bucket	10.3 m
B	Outside wheels	8.3 m
Inner wheels not braked		
A	Outside loader bucket	10.9 m
B	Outside wheels	8.76 m

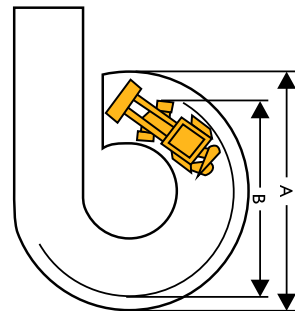

* Standard bucket in travel position

SPEED

Gear	Forward	Reverse
	Km/hr	Km/hr
1st	4.4	4.4
2nd	7.1	7.1
3rd	15.2	Not recommended
4th	28.8	Not recommended

(Standard tyres, with zero torque converter slip @ 2200 rpm)

HYDRAULICS

System pressure : 2610 p.s.i. (180 bar)

Pump type : Gear, double pump

Combined pump flow : 70.4 lpm @ 2200 rpm

Filtration through suction strainer and return line 'JCB filtromatic filter'

WEIGHT

Shipping kgs | 5220

SERVICE CAPACITIES

Hydraulic system	:	60.0 Lt.
Fuel tank	:	60.0 Lt.
Engine coolant	:	13.5 Lt.
Engine oil	:	8.0 Lt
Transmission	:	16.0 Lt
Rear axle	:	10.0 Lt

CANOPY

- Front glass with wiper provided for operator comfort while driving.
- Excellent operator safety.
- Floor mats and plenty of legroom minimises fatigue and provide extra comfort to the operator.
- Adjustable operator seat combined with ergonomically positioned controls and soft touch steering wheel allow an operator to work un-interruptedly for long hours.
- Canopy provides easy 'walk through' access. Other features include seat belt, large convex rear view mirror, front screen wiper, front and rear horn, hazard warning system, lockable tool box.
- Instrumentation panel is positioned on the right hand side and includes engine speed, engine hour, fuel level, water temperature and mobile charger. Easily visible while both end operation.
- Audio and visual fault warning system for alternator charging, coolant temperature, engine oil pressure, blocked air filter, transmission oil pressure and temperature and hand-brake on.

AXLES

- **Rear** : Drive axle rigidly mounted, incorporates JCB Max-Trac torque proportioning differential, driven by short propshaft from gear box.
- **Front** : 2WD steer axle, centrally pivoted, with oscillation angle of 16°.

OPTIONS

- Cabin
- High dump shovel (3.1 M)
- Heavy duty tyres
- 6-in-1 clam shovel
- Auger
- Dozer blade
- Range of excavator buckets

* All dimensions, weights and timings are variable within 1.5%, JCB reserves the right to change specifications without prior notice.