

NEW JCB NXT 215LC



THE NXT LEVEL

Gross Engine Power : 104 kW (140 hp) | Bucket Capacity : 0.8 cu.m - 1.02 cu.m
Operating Weight : 21,500 kg



JCB NXT 215_{LC}

THE NXT LEVEL



NXT LEVEL OF RELIABILITY

NXT LEVEL OF INTELLIGENCE

NXT LEVEL OF FUEL EFFICIENCY

NXT LEVEL OF CONNECT

NXT LEVEL OF MAINTENANCE

NXT LEVEL OF SAFETY

NXT LEVEL OF FUEL EFFICIENCY

Class-leading fuel efficiency with energy saving **ecoHydraulics**, offering more savings.



Innovative power management to minimise losses:

- Fuel consumption reduced up to 32%* in eco mode



JCB DYNAMIC EFFICIENCY

Optimises engine and hydraulic power to maximise savings.

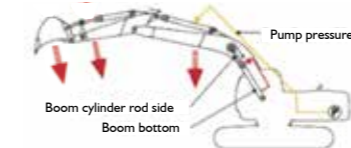

Boom, arm and bucket regeneration for faster operation and fuel saving.



Control valve with in-built flow summation for fast & efficient combined operations.

NXT LEVEL OF INTELLIGENCE

JCB presents an advanced excavation solution **IntelliControl** which optimises machine performance for output and fuel efficiency as well as it displays all key operating, maintenance and health related parameters on a large 7 inch LCD display leading to ease of machine usage.



First & largest in segment: 7 inch colour LCD screen



Dial type throttle



Quantity of fuel left (in litres)



Colour coded health alerts based on severity



Engine speed & operating mode status



Next service due information



Hammer over use indication



Rear view camera option

*T&C Apply.

NXT LEVEL OF CONNECT

Now be assured of your JCB excavator's service, operation and security with the advanced telematics system called the LiveLink with a host of new additional features.



Sudden fuel level drop alert



Fuel level monitoring



Idle time monitoring



Engine long idling count



Mode-wise breakup for machine usage



Hot engine shut down report



NXT LEVEL OF RELIABILITY

Reinforced structure made for longer life in tough strata.



Deep section boom design and internal reinforcement plates for higher strength



Long undercarriage (LC) with reinforced idler box area and doubler plate on X-frame

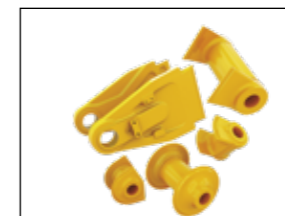

Reinforced cast ends of boom & arm for higher durability



Fully closed box section reduces damages

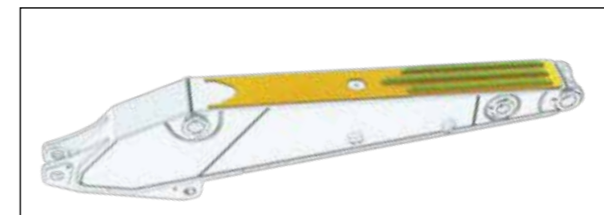

Heavy-duty reinforced arm

NXT LEVEL OF MAINTENANCE

Best-in-class service interval.

Service intervals on bucket operation	
Hydraulic oil	Every 5,000 hours
Hydraulic oil filters	Every 1,000 hours
Engine oil & oil filter	Every 500 hours

Class-leading maintenance interval



Critical health alerts

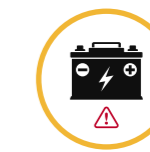

Battery disconnect switch

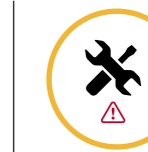

Service due reminder

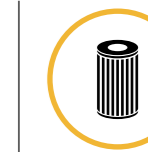

Radial seal air filter

First-in-class safety features



2 Go system



Selectable swing lock



Hydraulic accumulator



Hydraulic interlock to start engine



Engine & hydraulic overheat safety system

FABRICATION

1 High precision laser cutting technology is only used by JCB in the industry for excavator parts. This cutting-edge technology provides accurate profile cut parts, delivers stronger structures.

2 JCB is the first in the industry to use a bevel cutting robot, which gives an accuracy of 0.1mm to the parts, thereby ensuring best weld joints and strength to each component.

3 JCB uses the unique flattening rollers for 9-roll straightening process which makes the parts straight within 0.1mm. This ensures accuracy of manufacturing for excellent strength leading to stronger component.

4 The high precision CNC press bending used by JCB ensures reliability of the parts. This process delivers high precision and accurate bending of parts making them high quality and reliable, JCB has the biggest capacity for press brakes in India to deliver long parts without joints.

5 The unique hydraulic Jigs make every JCB part reliable, accurate and repeatable. The pre-defined control points in this machine give every part the desired accuracy and avoid any manual intervention.

6 JCB uses the latest vision system in the robotic welding to weld 100% parts of the excavators. This unique addition to the conventional robotic welding ensures precise weld position thereby, giving perfect structures for the excavators.

7 FARO dimensional Inspection is the latest technology used by JCB for quality assurance. This machine can measure the parts in few microns ensuring best-in-class machine components.

8 Ultra-sonic weld Inspection, the process being used only by JCB ensures zero defect in welding. This process checks internal weld integrity. 100% of the JCB parts go through this test.

9 The state-of-the-art duplex boring machine is used for the final process that ensures critical dimensions within 10 microns hence improving the quality of the assembly.

10 Bolstering JCB's promise of zero defect machine, is the pre-dispatch inspection. JCB experts carry out the PDI checks and other functional tests of each and every fabrication before assembly, thus making sure there is no fault forward.

NO FAULT FORWARD

made in **INDIA**
for the **WORLD**



1 Laser cutting technology



2 Bevel cutting robot



3 Unique flattening rollers



4 CNC press



5 Hydraulic jigs



6 Robot welding with camera vision system



7 FARO dimensional Inspection



8 Ultra-sonic weld inspection

NXT LEVEL OF RELIABILITY

STRENGTH INSIDE AND OUTSIDE.

Your most reliable partner

- 1 The heavy-duty boom uses deep section design and pivot ends made of cast steel for higher strength. The durability of the boom has been further enhanced with strengthened foot box section and increased weld strength on cylinder pivot section.
- 2 The heavy-duty upper frame has reinforced boom mounting area and offers closed box section design on side frame for high durability for tough working conditions.
- 3 JCB NXT 215LC comes with heavy-duty track link for long life thus reducing the maintenance cost and boosting machine uptime.
- 4 The JCB NXT 215LC comes with a reinforced arm with a full-length additional plate to enhance strength for high durability. Wear ribs are provided for damage protection in an arduous working environment.
- 5 JCB NXT 215LC offers Heavy-Duty X-frame design of track frame. LC version is available with strengthened idler area and doubler plates on X frame for enhanced strength. The heavy-duty track link assembly extends life and reduces maintenance cost.
- 6 Strong heavy-duty buckets are available as an option, designed to achieve easy fill and discharge while enabling a high level of bucket tear out in stone quarry application.

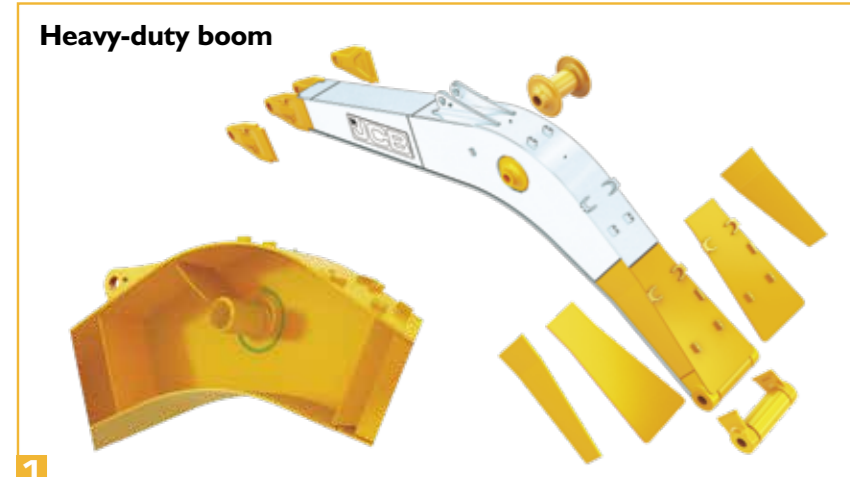

Heavy-duty upper frame



Heavy-duty undercarriage



Reinforced arm with additional full length strengthening plate at the bottom with wear ribs

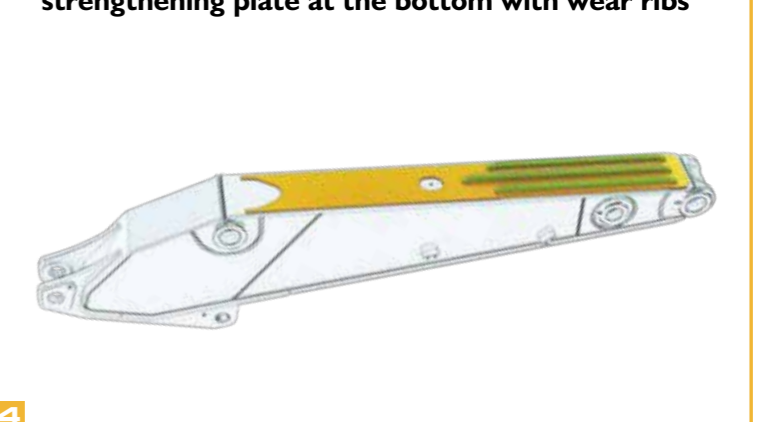

Heavy-duty X-frame



Heavy-duty bucket



7 The JCB NXT 215LC presents proven branded hydraulic components designed and manufactured to achieve long life, ensuring high uptime and reduce life-cycle maintenance costs.

8 The robust fuel filtration system in JCB NXT 215LC, presents high capacity fuel pre-filter with water separator, eliminates impurities & water from fuel and protects the fuel system, increasing machine uptime and lowering the maintenance cost.

9 New hydraulic return line filter comes with improved filtration efficiency to ensure high cleanliness level of hydraulic system which enhances life of hydraulic components. The rock-breaker piping, if fitted, comprises of a high efficiency rock-breaker return line filter to keep the hydraulic oil clean for long life of hydraulic components. A clog indicator is provided on rock-breaker return line filter to alert for proactive maintenance in case the filter is clogged.

10 The JCB NXT 215LC comes with unique dust and water-proof IP67/IP69 connectors with an electrical harness for trouble-free operation and high uptime.

11 The display in the JCB NXT 215LC is water and dustproof to provide long life in most demanding working conditions.

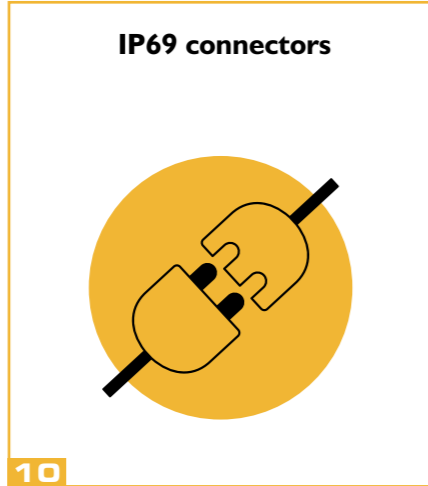
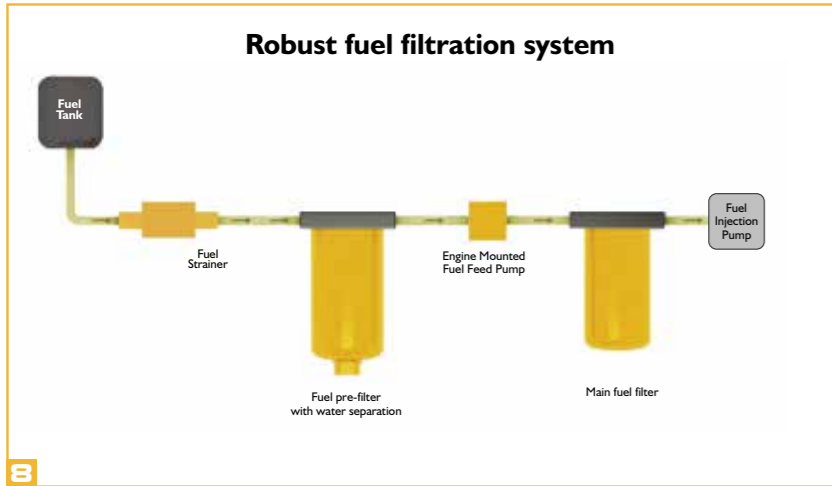
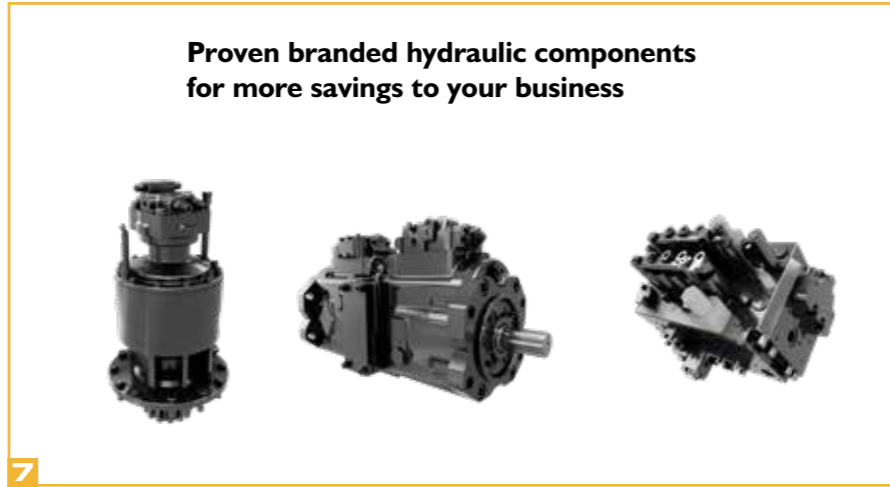

NXT LEVEL OF FUEL EFFICIENCY

THE BEST-IN-CLASS EFFICIENCY WITH ENERGY SAVING **ecoHYDRAULICS** OFFERS NXT LEVEL OF SAVINGS.

1 JCB NXT 215LC comes with best-in-class efficiency, as it is loaded with advanced hydraulic system and optimised pump control. The machinery comes with improved engine speed control and is specifically designed for lower energy consumption ensuring your business with more savings.

2 With one touch deceleration system, the JCB NXT 215LC boosts your savings, as the unique feature helps to reduce engine rpm by just giving one touch to the switch provided on RH joystick thus reducing fuel consumption.

3 The auto-idler feature in the JCB NXT 215LC automatically reduces engine rpm when the machine is not in use for 4 seconds. Lowering fuel consumption and increasing savings. The **IntelliControl** system enables the user to adjust this auto idle time as per requirement and convenience.

4 The JCB NXT 215LC comes with a unique attribute, that is a perfect combination of engine power and hydraulic power, helping to save on engine power resulting in leading fuel efficiency, thereby boosting your savings.

5 JCB NXT 215LC features **ecoHydraulics** which minimise the hydraulic losses resulting in enhance fuel efficiency, thus increasing savings.

6 The JCB NXT 215LC innovative hydraulic regeneration system recycles hydraulic oil across the cylinders for faster cycle times and reduced fuel consumption.



JCB
DYNAMIC
EFFICIENCY

Optimises engine and hydraulic power to maximise savings.



2

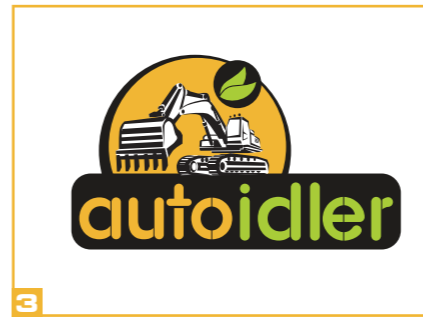

3

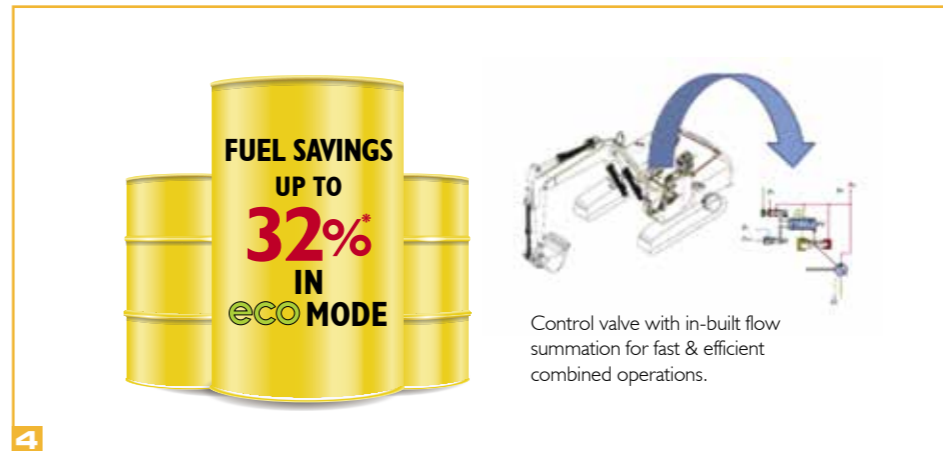

4



Regenerative hydraulic system

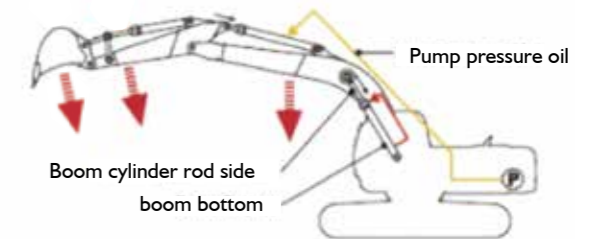

6

Regenerative circuits for higher operating speeds

NXT LEVEL OF PRODUCTIVITY

1 With ability to work in demanding conditions, the JCB NXT 215LC has excellent bucket digging force and dipper tear-out forces, resulting in higher output and faster completion of work, especially in hard strata. The optimised hydraulics ensure high productivity and more savings to your business, as it helps in faster multi-function performance leading to high output and low energy consumption.

2 The JCB NXT 215LC comes loaded with 3 Power modes - Eco, Power & Power plus. These 3 user-friendly power modes enable the operator to choose right machine working parameters as per the site condition & application, resulting in ease of work, faster job completion and enhanced productivity, keeping your business an edge ahead.

1 XCELLENT DIGGING

1



2

Power mode		Usage for
P+	Power plus	For maximum output Suitable for high output in heavy-duty strata
P	Power	For high output needs
eco	Economy	For general duty operations & low fuel consumption



3 The JCB NXT 215LC comes with options of bucket for a range of applications. These buckets are designed for efficient digging, easy fill and discharge of materials, thus resulting in increased earnings.

4 With high pressure settings, the JCB NXT 215LC gets more power for doing extra work even in hard strata, ensuring high productivity.

5 Faster swing speed of 13 rpm with swing torque of 65.2 kNm helps to complete the digging cycle in a minimum time & increases overall productivity of the machine.



5

NXT LEVEL OF COMFORT

A COMFORTABLE OPERATOR IS A PRODUCTIVE OPERATOR.

1 Best-in-class 7 inch digital colour monitor displays operational & maintenance parameters to keep the operator updated on the machine status. It displays power modes, working hours including attachment selection, trip hours, real-time fuel quantity and host of other information so that the operator can maximise machine output & uptime.

2 Thin and low effort joystick ensures fatigue-free operation for longer hours.

3 Easy to use rotary switch controls the engine speed and power modes selection as per the job requirement.

4 The fuel refilling pump option in JCB NXT 215LC ensures customers with time and manpower savings with auto stop features for hassle free fuel refills.

5 The large sized mirrors in JCB NXT 215LC ensure more machine safety and hassle-free operator working condition. The wiper wash in JCB NXT 215LC is provided for better front glass visibility.

6 Easy to open roof hatch assisted with 2 gas struts helps to keep the cab well ventilated. Higher visibility and safe operations with front top corner glass.

7 The JCB NXT 215LC comes with unique linkage arrangement for front glass lifting leading to effort and time saving, and large RH glass for excellent visibility.

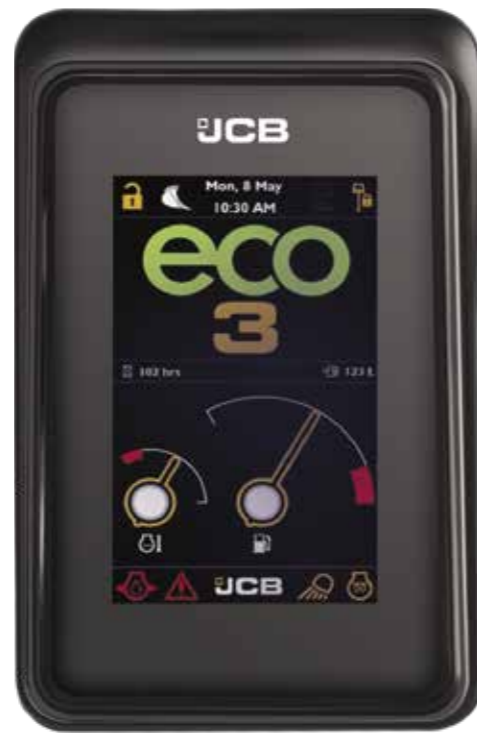

1



5



6



2

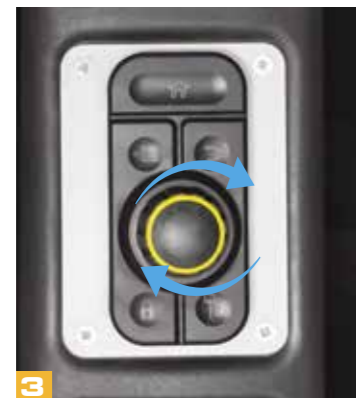

3

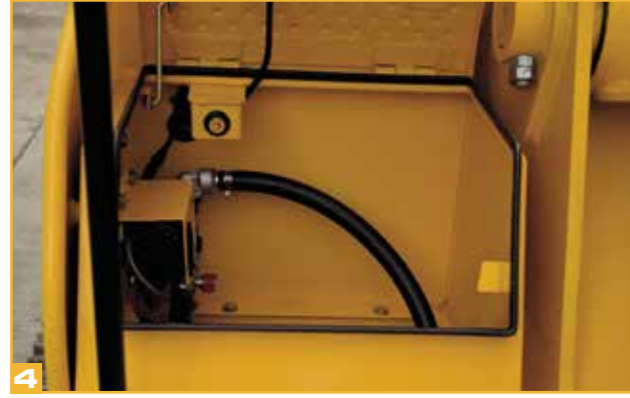

4



7



8 4 standard working lights: 2 on Cabin, 1 on the Boom-LH and 1 on toolbox.

2 Optional working lights: 1 on the counterweight and 1 on the Boom RH.

9 Wide and rubber-coated footrests provide excellent grip and excellent travel control.

10 The JCB NXT 215LC comes with tempered RH and front glass ensuring less breakage adding more life to the glass.

11 HD door locks ensure that side cowlings are always at their position to increase door life.

12 Powerful AC option to cool the cab with the multi-position wind outlet points from the back, front and bottom side.

13 New improved fully adjustable seat with increased reclining angle enhances backrest support gives excellent comfort to the operator and leads to fatigue-free operation for longer hours.

14 Cab is mounted on 6 nos. viscous mounts to absorb vibration that ensures comfort for the operator.

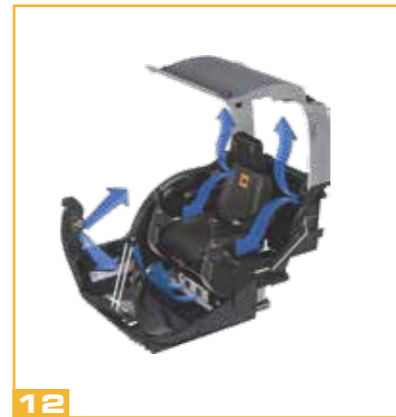
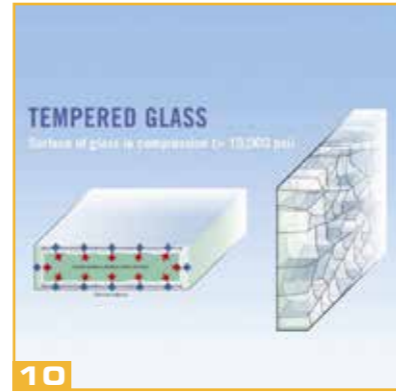



Introducing IntelliControl on the advanced JCB NXT 215Lc

BECAUSE INTELLIGENCE EMPOWERS

JCB presents an advanced excavation solution that shows you everything you want to see in real-time. The JCB NXT 215Lc is loaded with IntelliControl, giving you a complete view of the entire operations so that you can optimise your machine's performance and health. Experience intelligence, be empowered.



Digital anti-glare informative colour display

Operational information



Quantity of fuel left in tank



Engine speed & operating mode status



Trip meter



Auto idle status & time setting



Machine operating parameters



Rearview camera option

Maintenance information



Maintenance due information



Colour coded health alerts based on severity



Hour meter, counting of attachment operation



Easy diagnostic system



Service warning alerts

NXT LEVEL OF MAINTENANCE

THE DESIGN OF JCB NXT 215LC ENSURES EASE OF MAINTENANCE AND ALERTS ON DISPLAY WITH WHICH YOU CAN PLAN THE MAINTENANCE IN ADVANCE. GET THE NXT LEVEL OF MORE UPTIME, HIGHER MACHINE UTILISATION AND QUICK SERVICEABILITY.

- 1 Plan your work better with the maintenance reminders on the display, which gives information with regard to the hours left for next service. Refuel your machine on time, as the monitor displays the quantity of fuel left in the tank.
- 2 Advanced self-diagnosis system with error codes and multi-coloured warning alerts for easy and quick maintenance.
- 3 Display of all critical parameters, accessed through internal menu for easy health monitoring.
- 4 Independent breaker hour meter indicates the hours for breaker attachment usage, thus helping in maintenance planning.
- 5 Ensure safety of your machine with alerts about high engine coolant temperature, low engine oil pressure, low coolant level, clogged air filter & high hydraulic oil temperature.



Independent breaker hour meter



5 Wire mesh guard on the cooling pack to prevent entry of debris or any other objects in cooling pack. It protects the engine & hydraulic system from overheating, thereby providing ease of maintenance as well as higher machine uptime.

Side by side installation of engine radiator and oil cooler offers ease of cleaning while enhancing cooling efficiency of the system.

7 The engine bonnet is compact in size and is supported by a gas strut. It helps in easy and effortless handling of the bonnet during maintenance. It also provides the operator high rear end visibility.

8 Battery disconnect switch helps to isolate machine's electric system easily whenever required.



NXT LEVEL OF SAVINGS ON MAINTENANCE

THE JCB NXT 215_{LC} IS ENGINEERED TO GIVE YOU MORE PROFITS AND LESS MAINTENANCE COST. THE LONG SERVICE INTERVALS AND HIGH QUALITY PARTS GIVE YOU THE NXT ADVANTAGE OF LOWER DOWNTIME AND HIGHER PROFITS.

1 JCB NXT 215_{LC} carries an innovative filtration system that keeps hydraulic oil clean and extends hydraulic maintenance intervals, reducing cost. It reduces inventory as well as saves manpower time. Reduces maintenance cost & increases machine availability for productive work, giving more power to your business.

2 Pre-cleaner comes as standard in JCB NXT 215_{LC} ensuring longer air filter life, less maintenance cost & enhanced engine life.

3 Radial seal type air filter elements provide secure and error-free sealing, protect the engine from dust particles keeping it clean, thereby enhancing engine life. In addition, filter elements are covered with wire mesh to avoid damage.

4 Dimple design steel bushes are used at all pivots for ease of greasing & longer life.

SERVICE INTERVALS	
Hydraulic main filter	Every 1,000 hours
Hydraulic oil	Every 5,000 hours



NXT LEVEL OF SAFETY

SAFETY IS PRIMARY FOR JCB WHETHER IT IS OF THE MACHINE OR OF THE OPERATOR THEREBY, SERVING YOU WITH FIRST-IN-CLASS SAFETY PARTS AND FEATURES THAT ALSO ENSURE LOW DOWNTIME AND HIGHER PRODUCTIVITY.

1 Ensure higher uptime & better management of your fleet with an improved advanced telematics system - LiveLink 4.0. It helps the owners to know about several aspects of their machines including location tracking, machine utilisation report, machine health alerts, tow-away alerts, time curfew, geofencing and sudden drop in fuel level.

2 Hydraulic functions to avoid unintended movements: JCB's unique 2GO system ensures that the hydraulic operation of the new JCB NXT 215LC can only be started from locked position via two separate inputs, which avoids unintended machine operation.

3 Swing lock system enables the operator to lock the swing operations only, whenever required.

4 Anti-engine restart system & anti-over cranking system protect the starter motor from damage, thus ensuring longer starter motor life & higher uptime.

5 Hydraulic accumulator enables the operator to lower down the front attachment in case of any emergency without starting the engine.

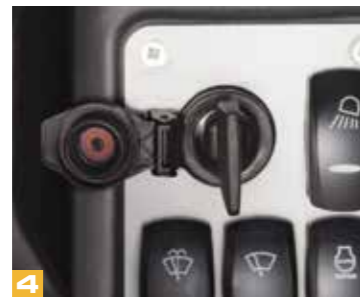

6 Belly-guard installed in the lower frame and plates under the upper frame protect the major components from external damage, enabling the machine to work in tough underfoot conditions.

7 Engine start interlock is provided to ensure safe start of the machine, the engine can be started only when the servo isolator lock is ON.

8 Laminated RH & front top glass resist the damage against impact and provide comfortable & safe working environment to the operator.

9 Rigidhand rails for better support while climbing on the machine.



NXT LEVEL OF CARE

Uptime technology

JCB's advanced telematics solution - LiveLink and Tech Web are innovative connectivity solutions that facilitate 24x7 monitoring of machines. Through the use of big data these help in determining field issues and trends which result in better and faster service mobility. Moreover, inputs and analysis of this data help in offering solutions for preventive maintenance.

Machine Uptime

The JCB LiveLink mobile app has been updated with an SOS feature that allows for an instant alert to be sent to JCB dealerships - all at the simple press of a button. This real-time, convenient solution empowers customers to login their service requests instantly thus ensuring 24x7 continuity of operations for their business.

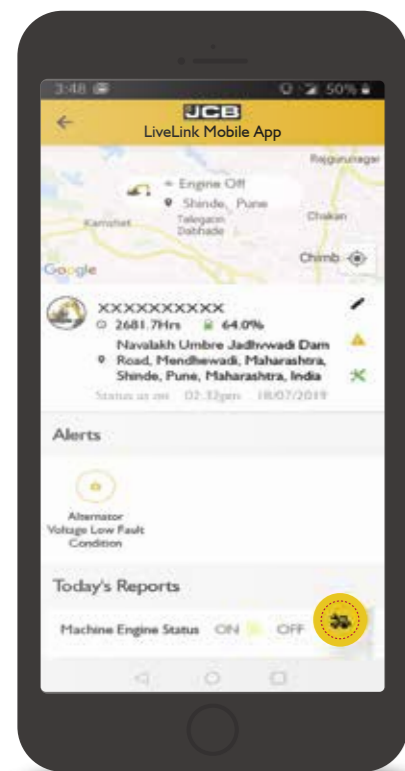

NXT LEVEL OF CARE

GIVE YOUR MACHINE EXTENDED WARRANTY AND CARE.

- JCB Careplus is an extended warranty programme that comes into effect after the machine standard warranty expires.
- JCB Careplus can be purchased within the 1st year from the sale of the machine.
- The programme offers you peace of mind and saves your maintenance cost even after your machine standard warranty expires.



BENEFITS OF JCB CAREPLUS

 No limits on number of claims	 Preventive maintenance service*	 Nationwide coverage*
 JCB skilled manpower support	 Maximum productivity	 Maximum uptime
 Maximum performance	 Breakdown cost protection	 Better resale value

*T&C Apply



NXT LEVEL OF CONNECT

NOW BE ASSURED OF YOUR JCB EXCAVATOR'S SERVICE, OPERATION AND SECURITY WITH THE ADVANCED TELEMATICS SYSTEM - LIVELINK*.

Security



In case of sudden drop in fuel level get an SMS/e-mail alert.



Alerts you via SMS/e-mail in case the machine is used outside the set hours.

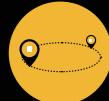

Helps to locate your machine precisely on the map to display its current location.



Get SMS/e-mail alerts in case the machine moves out of the geofenced area.



Alerts you via SMS/e-mail in case the machine is being towed away even in engine off condition.

Operation & performance monitoring



Idle time monitoring helps in analysing the extent to which engine was idle. This can be used for better site management to minimise idle hours and save fuel consumption.



Machine usage can be monitored in detail including the hours worked in each mode.



Instantaneous fuel level monitoring.

Reports & alerts



Customised reports on performance, utilisation, fleet summary, landmark activity, machine hours and service status.



Easier fleet management.



Periodic reports - daily, weekly, monthly or as required.



Machine status and critical health alerts.

Proactive maintenance & usage



Maintenance reminders.



Alerts are provided in case any critical health parameter needs attention. Such alerts are displayed on the dashboard of the LiveLink website. These are sent by e-mail/ SMS.

Safety



Engine high rpm shut down report: Know the number of times the engine shuts down while working at high speeds.



Long engine idling report: Know the number of times the machine idles for a long time, minimising idle hours and saving fuel.



Critical health alerts on the parameter which needs immediate attention.

User-friendly reports

Engine on-off time

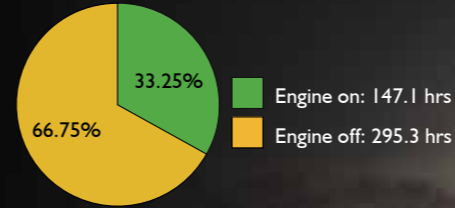

Working & idle time

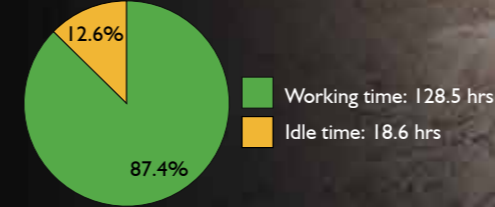

Power mode

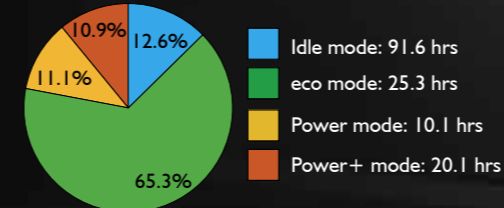

Advanced
LIVE JCB LINK
4.0
Stay connected 24x7



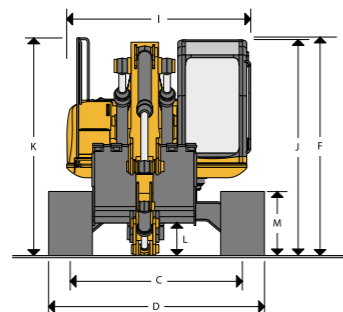
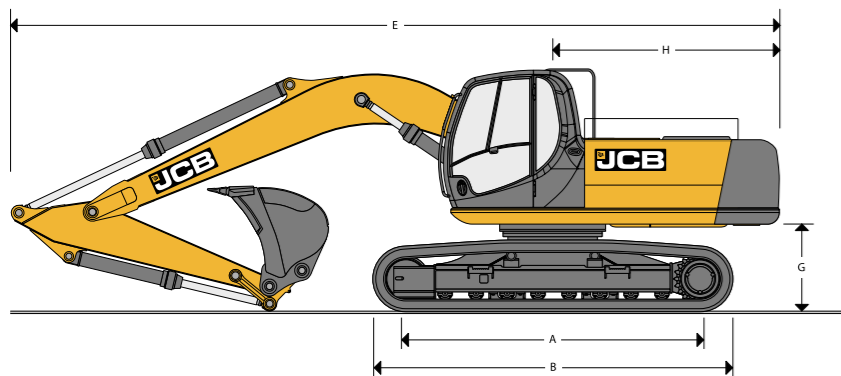

WEIGHT AND GROUND BEARING PRESSURE	
Standard machine with bucket, operator, full capacity lubes and fuel	
	JCB NXT 215Lc
Max operating weight	21,500 kg
Ground bearing pressure	0.49 kg / sq cm

STATIC DIMENSIONS		JCB NXT 215Lc (LC track, 600 mm track shoe)	
		2.4 m arm	3 m arm
A	Track length on ground	3.66	3.66
B	Undercarriage overall length	4.46	4.46
C	Track gauge	2.39	2.39
D	Width over tracks	2.89	2.89
E	Transport length with mono boom and arm	9.63	9.56
F	Transport height with mono boom and dipper	3.12	3.12
G	Counterweight clearance	1.08	1.08
H	Tailswing radius	2.83	2.83
I	Width of superstructure	2.55	2.55
J	Height over cab	3.06	3.06
L	Ground clearance	435	435
M	Track height	885	885

ENGINE

Model	: Cummins 6 BT 5.9C
Type	: Water cooled, 4 stroke, 6 cylinder in line direct injection, turbo-charged diesel.
Gross Power	: 140 HP @2000 rpm
Piston displacement	: 5.88 L
Max torque	: 571 N-m @ 1300 rpm
Bore X Stroke	: 102 mm X 120 mm
Starting system	: 24 volt.
Alternator	: 24V, 75 amp, heavy-duty

SERVICE CAPACITIES

Fuel tank	343 L
Engine coolant	25.5 L
Engine oil	19 L
Hydraulic system	260 L
Hydraulic tank	120 L
Swing device	5 L
Travel device	2 x 5 L

CAB + CAB GUARD

Pressed steel construction with high strength rolled sections. Excellent all-round visibility during digging, loading & positioning. Removable front lower glass and sliding rear window. Excellent ergonomic positioning of operating levers for reduced operator fatigue. Fully ducted AC for operator comfort. Windscreen wiper, FM radio with USB media player with speakers, mobile phone charging point & lockable stowage available. Rubber covered track pedal, water bottle & document holders provided. Front cab guards available for protection against flying objects. Additional cab top lights for illumination.

EXCAVATOR BUCKET

All buckets are JCB type fully welded steel, with sealed, hardened steel pivot pins and replaceable wear parts.

Bucket	Toe plate width (m)
0.9 cu.m (GP)	1.18
0.9 cu.m (HD)	1.22
1.02 cu.m (GP)	1.32
0.8 cu.m (Rock)	1.14

TRAVEL SPEED & TRACTIVE EFFORT

Travel speed	3.8 kmph
Tractive force	170 kN

WORKING RANGE

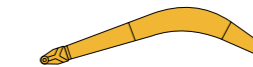

Boom length 5.7 m	Unit	Arm length	
		2.40 m	3.00 m
A Maximum digging reach	m	9.4	9.9
B Maximum digging reach (on ground)	m	9.21	9.72
C Maximum digging depth	m	6.14	6.73
D Maximum digging height	m	9.13	9.22
E Maximum dumping height	m	6.36	6.49
F Maximum vertical wall cut depth	m	5.57	6.06
G Minimum swing radius	m	3.84	3.8
Bucket rotation	deg.	177	177
Dipper tearout (ISO)	kgf	11832.0	9845.0
Bucket tearout (ISO)	kgf	13460.0	13460.0

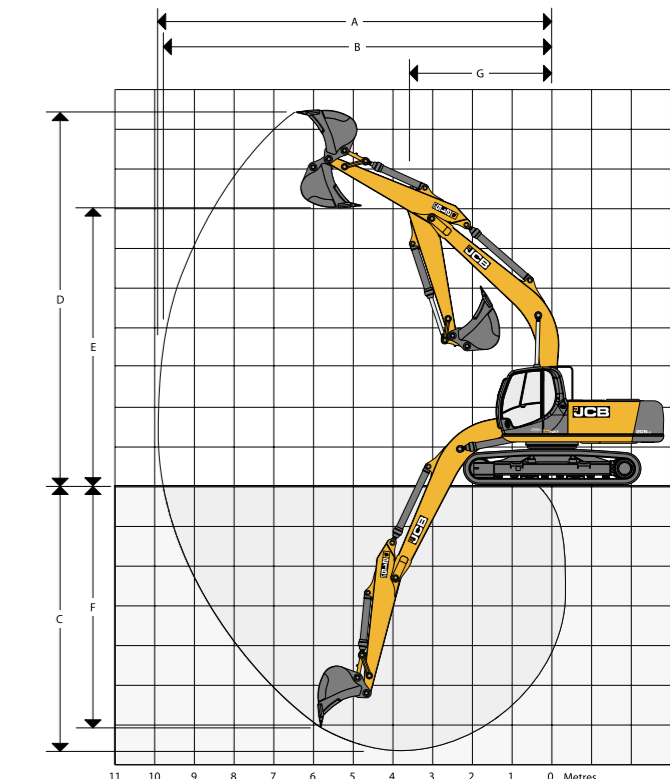

SWING SYSTEM

Swing motor	: Axial piston type.
Swing brake	: Hydraulic braking, electrically operated spring applied disc type parking brake.
Final drive	: Planetary reduction.
Swing torque	: 65.2 kNm
Swing gear	: Large diameter, internally toothed fully sealed grease bath lubricated.
Swing speed	: 13.0 RPM

HYDRAULIC SYSTEM

A variable flow load sensing system with flow on demand, variable power output and servo-operated, multi-function open central control.

3 Work modes: eco, Power & Power+

Pumps

Main pumps	: 2 variable displacement axial piston type.
------------	--

Maximum flow	: 2 x 220 L/min
--------------	-----------------

Servo pump	: Gear type.
------------	--------------

Maximum flow	: 20 L/min
--------------	------------

Control valve

A combined four and five spool control valve with auxiliary service spool as standard. When required twin pump flow is combined to boom, dipper and bucket services for greater speed and efficiency.

Relief valve settings

Boom / Arm / Bucket	: 343 bar
---------------------	-----------

Swing circuit	: 289 bar
---------------	-----------

Travel circuit	: 343 bar
----------------	-----------

Pilot control	: 40 bar
---------------	----------

Main control valve	: 9 Spool
--------------------	-----------

CONTROLS

Excavator : All servo lever operated to ISO control pattern

Engine auto-idler : Reduces engine speed to low idle depending upon machine utilisation thus saving fuel.

Tracks : Individually servo-operated by a foot pedal or hand lever

Auxiliary : Via servo-operated foot pedal.

Horn : Operated via servo lever mounted button.

UNDERCARRIAGE

Construction: Standard/Long undercarriage fully welded. X-frame type with central belly guarding and sloping side members with dirt relief holes under top rollers.

	JCB NXT 215Lc
Track Shoe	600 mm (standard)
Upper & lower rollers	Heat-treated, sealed and lubricated.
Track adjustment	Sealed and lubricated, with spring enhanced recoil.
No. of track guides	2 per side
No. of lower rollers	8 Per side
No. of upper rollers	2 per side
No. of track shoes	49 per side

STANDARD EQUIPMENT

FM Radio and USB music player with speakers

Auto-Idler

4 standard working lights: 2 on Cabin, 1 on the Boom-LH and 1 on toolbox

Windscreen wiper

Engine fan guard

Undercarriage belly guarding

Upper structure under covers

Engine pre-cleaner

Double element radial type air cleaner

with wire mesh protection

Heavy-duty alternator (75 amp)

Cabin fan

Suspension seat

Cab floor mat

Rubber covered track pedals

Removable front lower cab glass

Hammer pipe mounting brackets

Tool Kit

Handrail and non-slip walkways

Radiator fly screen

LiveLink

Cabin guard (Front)

Fully ducted air conditioner unit

OPTIONAL EQUIPMENT

Cabin guard (Top)

Rock breaker

Rock breaker pipe work.

Working lights: 1 on the counterweight and 1 on the Boom RH

General-purpose buckets (0.9 cu.m, 1.02 cu.m, 1.15 cu.m & 1.2 cu.m)

Coal bucket (1.7 cu.m)

Waste handling bucket (1.2 cu.m)

Heavy-duty buckets (0.8 cu.m, 0.9 cu.m, 1.02 cu.m)

First aid kit

Fire extinguisher

Long reach attachment (15 m)

Cab sun screen

3 m arm

Refuel pump



TRACK DRIVE

Type : Fully hydrostatic

Travel motors : Axial piston type, fully guarded within undercarriage frame.

Final drive : Planetary reduction, bolt-on sprockets

Service brake : Hydraulic counterbalance valve to prevent over speeding on gradients.

Park brake : Disc type, spring applied, automatic hydraulic release.

Gradeability	: 70% (35 deg.) continuous
--------------	----------------------------

Travel speed	: 3.8 kmph
--------------	------------

Tractive effort	: 170 kN
-----------------	----------

EXCAVATOR END

Deep section design of boom & arm with cast ends & pivot bosses with braker pipe mounting provision.

FILTRATION SYSTEM

The hydraulic components are protected by the highest standard of filtration to ensure long hydraulic fluid life up to 5000 hrs (subject to SOS & recommended maintenance practices) and component life.

In tank : 150 micron, suction strainer

Main return line : 10 micron, fibre form element

Pilot line : 10 micron, paper element

Hydraulic hammer return : 10 micron, reinforced micro-form element.

Cooling : Cooling is provided via full return line air blast cooler with anti-block wavy cooling fins. Fly mesh provided to avoid clogging of radiator and cooler films.

LIFT CAPACITIES

Reach	3 m		4.5 m		6.0 m		7.5 m		Capacity at max. reach	
Load point height										

JCB NXT 215Lc LIFT CAPACITIES : Arm 2.4 m, Tracks : 49 Links, Track shoes : 600 mm, without bucket

Reach	3 m		4.5 m		6 m		7.5 m		Max. Reach		Max. Reach
Load point height	Kg	Kg	Kg	Kg	Kg	Kg	Kg	Kg	Kg	Kg	m
7.5 m									5830*	5550	5.53
6 m					5630*	4970			5580*	4060	6.76
4.5 m			7130*	7130*	6110*	4830			5200*	3390	7.47
3-0 m			9020*	7000	6940	4610	5100	3300	4130	3060	7.87
1.5 m			10630	6580	6900	4400	5000	3210	4590	2950	7.95
0 m			10820	6380	6840	4260	4930	3140	4720	3020	7.74
-1.5 m	11210*	11210*	10780	6350	6790	4220			5210	3310	7.22
-3.0 m	14070*	12620	10190	6450	7830	9830			6410	4040	6.30
-4.5 m	10600*	10600*	7520*	6730					6930*	6210	4.76

JCB NXT 215Lc LIFT CAPACITIES : A rm 3 m, Tracks : 49 Links, Track shoes : 600 mm, without bucket

Reach	3 m		4.5 m		6 m		7.5 m		Max. Reach		Max. Reach
Load point height	Kg	Kg	Kg	Kg	Kg	Kg	Kg	Kg	Kg	Kg	m
7.5 m									4130*	4130	6.23
6 m									3870*	3590	7.33
4.5 m					5530*	4880	5230	3410	3840*	3040	8.01
3-0 m	12490	12490	8140*	7140	6420	4690	5110	3310	3970	2770	8.37
1.5 m			9960	6630	7000	4400	4980	3190	4170	2670	8.44
0 m	6660	6660	10790	6340	6800	4230	4880	3100	4260	2710	8.25
-1.5 m	11050*	11050*	10680	6250	6710	4150	4850	3060	4620	2930	7.76
-3.0 m	15210*	12330	10630	6300	6740	4170			5490	3460	6.92
-4.5 m	12430*	12430	8850*	6990					6850*	4820	5.55

Lift capacity front and rear

Lift capacity full circle

Notes: • For lifting capacity including bucket, subtract total weight of bucket or bucket and quick hitch from above value • The above loads are in compliance with SAE and ISO standards i.e. 75% of minimum tipping load or 87% of hydraulic lift capacity, whichever is less. Lifting capacities marked * are based on hydraulic capacity.