

**NEW**

JCB 30PLUS | MINI EXCAVATOR



**Compact in size. High on performance**

Operating Weight: 2870kg, Net Engine Power: 18.4kW (24.7 hp)



## MINI BUT MIGHTY

NO ONE KNOWS BETTER THAN JCB HOW TO BUILD A ROBUST EXCAVATOR. THE JCB 30PLUS IS THE PRODUCT OF OUR VAST EXPERIENCE AND KNOW HOW IN THIS SECTOR. TROUBLE-FREE, SOLID AS A ROCK AND BUILT TO LAST. IT MAY BE MINI, BUT IT'S MIGHTY.



### High strength undercarriage

1 The JCB 30PLUS's high-quality 250mm wide steel tracks with interlocking links perform in the most arduous applications.

2 High-strength track legs boast three-piece fabrication to maximise rigidity and improve track retention. Chamfered edges reduce spoil retention and makes the undercarriage easier to clean. The JCB 30PLUS open-centre track frame design also prevents the build up of spoil.

3 Our new undercarriage features a top mounted roller enhancing track durability.

4 Box section dozer arms provide ultimate strength and robustness for all dozer duties.

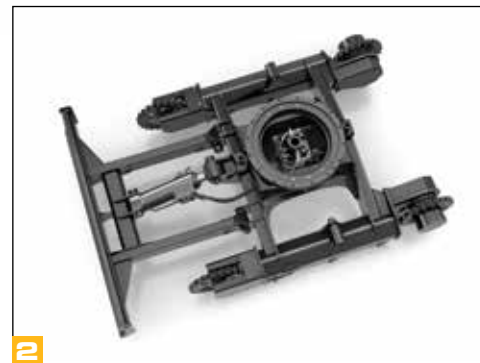

**Reliable and robust**

- The JCB 30PLUS features colour coded hydraulic hoses for quick hose identification and boasts the latest industry technology "O-Ring Face Seal" (ORFS) hydraulic fittings providing excellent sealing capabilities.
- Fast cycle times give excellent productivity.
- The JCB 30PLUS's new cast tread plate helps to prevent paint damage when accessing the cab.
- Recessed bonnets and a robust rear cast counterweight provides extra damage protection.

**Built to last**

- JCB state-of-the-art manufacturing is 100% focused on build quality, reliability and durability to maximise service life and machine uptime.

Our in-house paint process guarantees quality and lasting protection.



6



5



7



8



9

## PRODUCTIVITY REACHES NEW HEIGHTS

AN OUT-AND-OUT CLASS LEADER WHEN IT COMES TO LIFTING AND STABILITY, COMBINED WITH HIGH TRACTIVE EFFORT, TRACKING SPEED AND PUSHING POWER. THE JCB 30PLUS TAKES PRODUCTIVITY TO NEW HEIGHTS.

### Deeper

1 New dig-end geometry for superior excavator performance: 2.74 m depth, 4.77 m reach, 3.22 m dump height.

### Higher, further

2 Maxi-lift dozer ram allows extra lift height even when the dipper is at maximum reach. In addition the super powerful hydraulics gives excellent load hold performance.

### Tractive effort and manoeuvrability

2 The JCB 30PLUS boasts 12% greater tractive effort than its closest rival with the added benefit of improved spin turn.



**Power, performance and stability**

At the heart of the JCB 30PLUS is a 18.4kW (gross) BS III engine developing high torque of 96kN at 1800rpm for ultimate performance and efficiency. The engine is cooled by a large heavy duty cooling pack.

A solid, stable work platform improves productivity, lift capacity and operator confidence.

Impressive bucket and dipper tearout performance (23kN and 17kN respectively) coupled with fast cycle times result in high productivity and better efficiency

Superior boom geometry and bucket rotation gives improved soil retention and the ability to dig right up to the dozer.

**Versatility**

26% more auxiliary flow than the competition provides ultimate in attachment power.

The bucket-to-grab auxiliary changeover switches oil flow from the bucket cylinder to an additional set of quick-release auxiliary connectors, extending versatility to specialised attachments, such as an auger.

The machine is available with a variety of attachments including quickhitch, soil drill and JCB Hammermaster HM 140.



10



6



7



9



9

## DESIGNED TO MAKE LIFE EASIER

MAKING LIFE EASIER MEANS PUTTING THE OPERATOR FIRST. THE JCB 30PLUS GIVES PRECISION CONTROL IN A SAFE AND COMFORTABLE ENVIRONMENT. SERVICING IS QUICK AND SIMPLE.

### Precision control

1 The new hydraulic system results in smooth, controlled, precise and balanced operation of the excavator it also has low effort oil pilot operated servo joysticks.



### Comfort and visibility

2 The new JCB 30PLUS features a number of enhancements that improve the operator comfort.

- Bottle holder
- Face fan
- Rubber foot track pedals
- Rear view mirror
- 12V charging point
- Under seat tool box
- Improved seating
- Wipe clean roof lining





**Maintenance made easy**

7 The new hydraulic valve block is easily accessed beneath the side-opening bonnet. All hoses are colour coded for quick and easy identification in the event of accidental damage.

8 Hinged cast tread plate gives simple battery access – just use a coin or screwdriver to unlock.

9 Pin end greasing makes lubricating the dig end quick and easy.

10 A large 56-litre fuel tank enables continual operation for long hours.

11 New cabin mounted work lights give effective illumination of the work area.

**Safe and sound**

All JCB 30PLUS services, including tracking and dozer, are isolated when the control pod is raised.



Wide-opening service access panels are supported by gas struts for excellent access to routine checks.



**Trenching**



**Grading**



**Transportation**



**Site clearance**



**Dozing**



**Bulk material handling**



**Digging bucket**



**Offset digging**



**Service access**



**Pipeline and lifting**



**JCB HMI40 Hammer**



**Auger**



**Restricted access backfilling**



**Trolley loading**



**Bush clearance**



# JCB 30PLUS MINI TRACKED EXCAVATOR | SPECIFICATION

The NEW JCB 30PLUS Mini Tracked Excavator is made in India with following best-in-class features

- High reliability with best-in-class service access
- Comfortable operator environment with insulated track pedals
- High manoeuvrability for working in restricted areas
- Fuel efficient to reduce operating cost
- Best backup and parts availability in the industry from JCB dealer network

## OPERATOR ENVIRONMENT

Canopy height	mm	1517
Canopy length	mm	1205
Canopy width	mm	980

## SERVICE CAPACITIES

Fuel tank	litres	56
Engine coolant	litres	8.5
Engine oil	litres	4.5
Hydraulic system	litres	71
Hydraulic tank	litres	45
Track gear box (side)		

## DOZER BLADE

Max height (above ground)	mm	333
Dig depth (below ground)	mm	405
Approach angle	degrees	31
Width	mm	1550
Height	mm	268
Reach in front of tracks	mm	342

## MACHINE WEIGHTS

Operating Weight*	kg	2,870
-------------------	----	-------

Solid pins with greasing in ram eye and protected

\*Operating weight to ISO 6016 including canopy with steel tracks

\* All dimensions, weights and timings are variable within 1.5% JCB reserves the right to change specifications without prior notice.



GROSS ENGINE POWER : 24.7 hp  
MAX. OPERATING WEIGHT : 2870 kg

## STANDARD SPECIFICATION

ROPS & TOPS certified canopy, with roof trim full audio/ visual warning systems, slew travel lock, control isolator, internal lockable toolbox, 12v power socket, lifting points, 250 mm steel tracks, ISO servo controls, static seat, track insulated pedals, boom ram protection, maxi-lift dozer blade, 1300 mm dipper, auto kickdown track motors, canopy worklights, 450 m (0.054m<sup>2</sup>) bucket, bushed king post. Face fan, bottle holder, canopy work light, auxiliary Circuit.

## ADDITIONAL EQUIPMENT AVAILABLE

Bucket Type	Width (mm)	Capacity (cum)
General Purpose	230	0.023
	450	0.054
	600	0.074
Ditching Bucket	1000	0.076

Fully insulated canopy area for operator comfort new grab handles for improved access and egress 2 cab mounted work light and one boom work light with protection.

# JCB 30PLUS MINI TRACKED EXCAVATOR I SPECIFICATION

GROSS ENGINE POWER : 24.7 hp  
MAX. OPERATING WEIGHT : 2870 kg

## STATIC DIMENSIONS

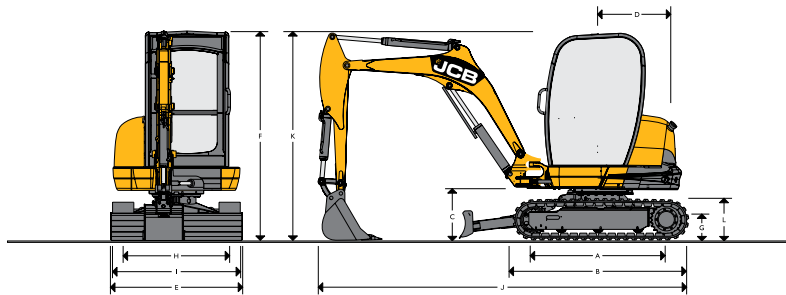

Machine model		JCB 30PLUS
A Sprocket idler centres	mm	1440
B Undercarriage overall length	mm	1870
C Kingpost clearance	mm	528
D Tailswing radius	mm	1220
E Overall width of superstructure	mm	1550
F Height over canopy	mm	2400
G Ground clearance	mm	270
H Track gauge	mm	1252
I Width over tracks	mm	1502
J Transport length	mm	4080
K Transport height	mm	2400
L Track height	mm	455

## ENGINE

Model		Perkins 403D-I5
Fuel		Diesel
Cooling		Water cooled
Gross power	kW (hp) @ 2100 rpm	18.4 (24.7)
Net power	kW (hp) @ 2100 rpm	16.5 (22.1)
Gross torque	Nm (lbf ft) @ 1800 rpm	96 (70.8)
Net torque	Nm (lbf ft) @ 1800 rpm	90.4 (66.7)
Displacement	cc	1496
Gradeability	degrees	36
Starter motor	kW(hp)	2 (2.68)
Battery	volt/Ah	12 / 75
Alternator	amps	65

## UNDERCARRIAGE

No of bottom rollers		3
Track width	mm	250
Ground bearing pressure	kg/cm <sup>2</sup>	0.40
Ground clearance	mm	270
Track tensioning		Grease
Travel speed - low	kph (mph)	2.5 (1.6)
Travel speed - high	kph (mph)	4.9 (3.0)
Tractive effort	kN (lbf)	25 (5620)

## HYDRAULIC SYSTEM

Hydraulic pump		2 Variable & I Gear
Gear pump @ 2250 rpm	lpm	70.2l/min
Nominal output @ 2250 rpm		25.875/min
Excavator/track main relief	bar (psi)	235 (3408)
Slew main relief	bar (psi)	190 (2756)
Auxiliary hydraulic flow	litres	59 (15.6)

## WORKING RANGE

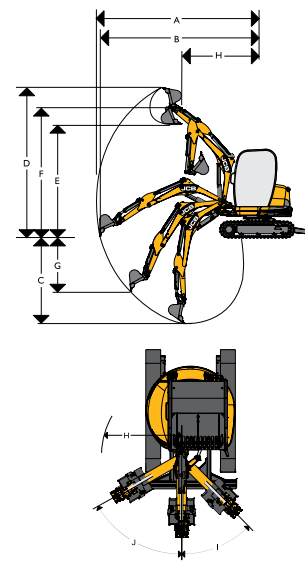

Boom length	mm	2130
Dipper length	mm	1300
A Max digging reach	mm	4770
B Max digging reach on ground	mm	4660
C Max digging depth-dozer up	mm	2740
Max digging depth - dozer down	mm	3050
D Max digging height	mm	4495
E Max dump height	mm	3220
F Max height to dipper nose pivot pin	mm	3830
G Max vertical wallcut depth	mm	2080
H Min. front swing radius (no offset)	mm	2045
Min. front swing radius (fully offset)	mm	1870
I Boom swing left	degrees	45
J Boom swing right	degrees	60
Bucket rotation	degrees	189
Dipper rotation	degrees	119
Bucket tearout	kN	23
Dipper tearout	kN	17
Slew speed	rpm	9.6

\* All dimensions, weights and timings are variable within 1.5% JCB reserves the right to change specifications without prior notice.